

PolyPrep Elite

Liquid Polymer Activation System

OUR STRENGTHS

Chemical Dosing
Integrated Controls
System Design
Systems Integration
Application Knowledge
Quality Engineering
Nimble Flexibility
Customer Service
Field Service

WE DELIVER

Custom Systems
Standard Systems
Metering Pumps
Controls
Instrumentation
Accessories

MARKETS SERVED

Municipal
Industrial
Commercial

APPLICATIONS

Cooling
Boiler
Process
Potable
Waste Water

1450 W. Fullerton Avenue
Addison, Illinois 60101

Phone: 630.543.1911
Fax : 630.543.2089

www.chemflow.com



- Automatic Batch Preparation
- PID Loop Control of Polymer Concentration
- Flush Cycle
- Water and Polymer Alarm
- Hot Duty Standby Switch Over
- Selectable Level Of Automation
- Control of Neat and Solution Tank Mixers
- Stainless Steel Frame
- NEMA 4X Stainless Steel Enclosure
- Water Supply Range: 10-100 GPM
- Stainless Steel Threaded Coupling Connections
- Dimensions – 72H x 34W x 50D

The PolyPrep Elite Series is designed for applications where polymer is process critical. Chem-Flow has taken all the guesswork out of polymer preparation and designed a system that provides the operator with ease of operation and the plant with certainty that a consistent solution will be provided to the process.

The system is managed by a PLC, but even if the PLC fails you can switch to a basic relay logic operation to keep your plant up and running.

In Full Auto mode the system will consistently make up to the concentration set between 0.25% and 1.5% no matter where the water fluctuates within 60% of the systems capacity. This means that your polymer system will not drop out due to a water alarm because of water fluctuations in your plant.

Polymer is measured and if low polymer occurs, the system will first try to speed up the current pump, if this does not solve the problem the second pump with auto start and take over. If this fails to solve the problem the system will stop and raise a full alarm.

The system is a complete solution and provides logic and motor starters for bulk storage mixing, solution tank mixing, booster pump, biocide dosing into polymer (if required), flushing cycle to clean the check valves, batch counter, run time monitor, and a full range of alarms that can be wired to your plant control system.

Quite simply the Elite series IS the Benchmark. No other system has the functionality, features and control of the Elite. Best of all the Elite is priced to be comparable to other systems not featuring this level of control or redundancy.

MODEL	CAPACITY
PE-1010	10 GPM
PE-1010	20 GPM
PE-1060	60 GPM
PE-1100	100 GPM

Contact us for additional information.



PolyPrep Elite Liquid Polymer Activation System

GENERAL ARRANGEMENT

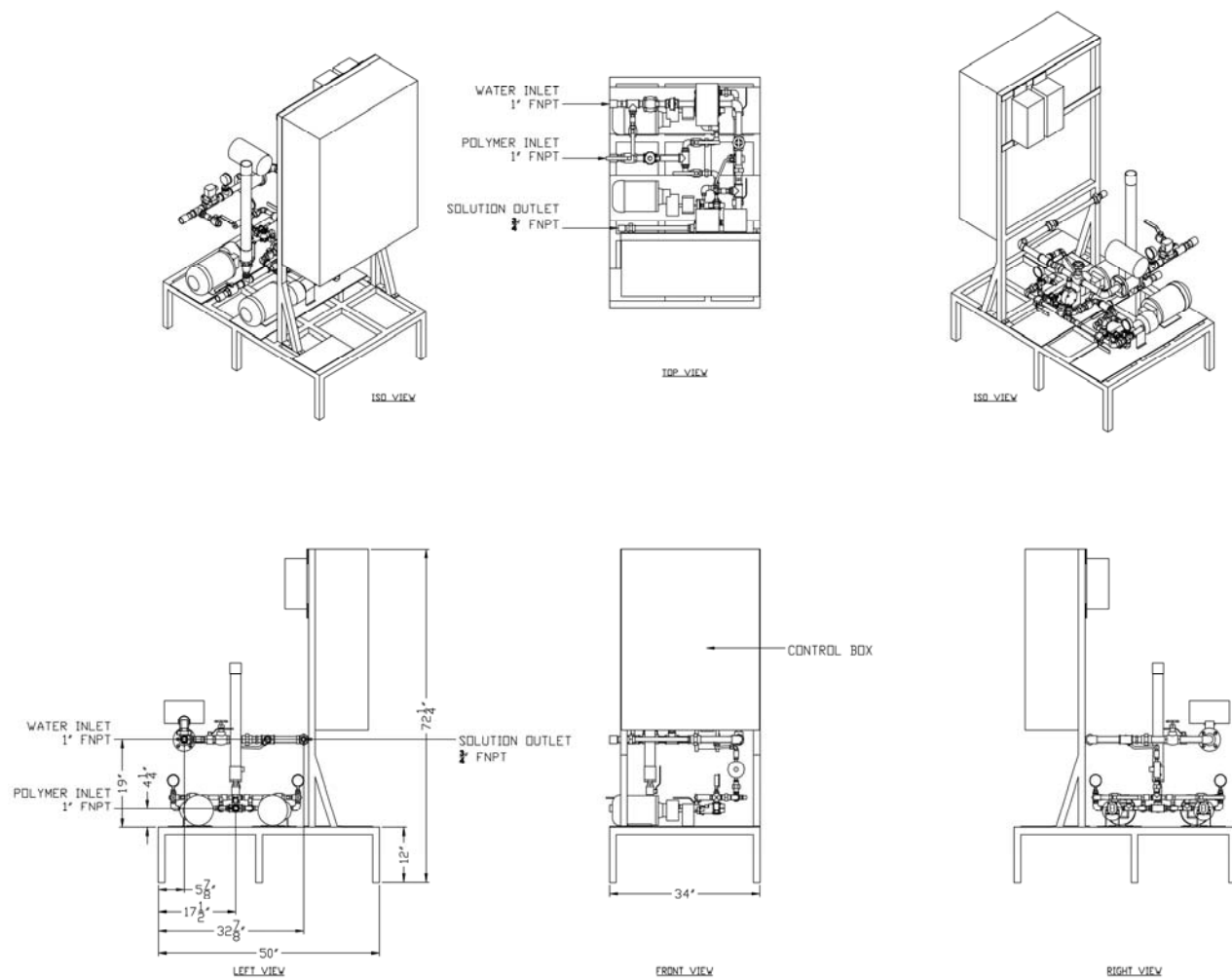

P&I DRAWING

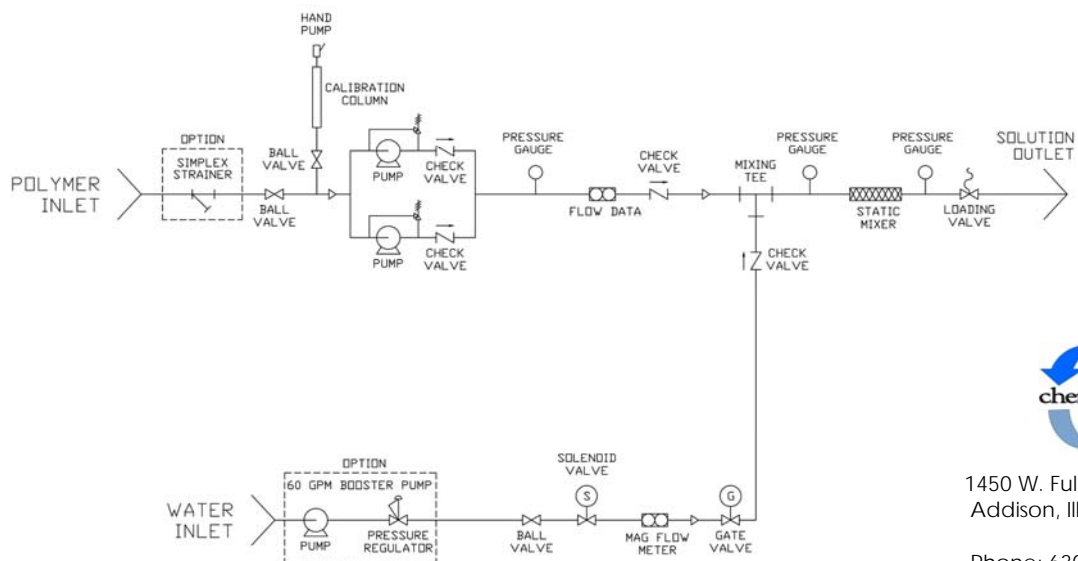

1450 W. Fullerton Avenue
Addison, Illinois 60101

Phone: 630.543.1911
Fax : 630.543.2089

www.chemflow.com