

OVERVIEW

The WCT400/410 Cooling Tower Controllers represent the latest in technological and innovative advancements from Walchem. All of the standard features you'd expect from a conventional cooling tower controller are included, plus optional simple-to-use information management tools that enable water treatment professionals to deliver more effective service to their customers.

The WCT400/410 controllers have the ability to store conductivity and temperature values, water usage, relay and flow switch status, and user settings. A USB memory stick is all that's needed to extract the information. Download logs from the USB stick to a PC at your convenience, or copy your preferred treatment program settings to another controller to speed start-up. It couldn't be easier!



SUMMARY OF KEY BENEFITS



Ensures Optimal Performance and Maximum Efficiency

Precise control of conductivity and chemical feed reduces water consumption and inhibits corrosion, solids precipitation, scale build-up, and growth of algae or dangerous bacteria.



More Informative Monthly Reports

Download stored data from the controller to a USB flash stick. Use the data to easily develop reports that show actual water usage, system conductivity, temperature, and more.



Efficient Customer Service

Quickly identify system upsets by knowing exactly what happened and when. An event log can be downloaded to tell you precisely when pumps turned on, valves opened, and when there was flow or no-flow.



Validation and Verification Made Easy

Use stored data from the controller to simply and easily validate water treatment results. The data and event logs show water usage, system conductivity, and temperature, as well as accumulated chemical feed and bleed times.



Save Time

Copy the user settings from your controller to a USB flash stick and upload to a new controller. Programming your new controller this way can be accomplished in seconds. It's that simple!

WCT400 Series | Feed and Bleed Cooling Tower Controller

» Four chemical feed options

- Feed & bleed, with or without feed lockout timer
- Feed after bleed has finished, as a percentage of time
- Feed as a percentage of time elapsed
- Feed as a percentage of make-up water

» Self-Diagnostics

- Software, electronics, and sensor are constantly monitored without having to take controller offline.

» Conductivity Electrodes

- Graphite or stainless steel
- Low pressure or high pressure
- In-line or submersion

» 4-20mA Output

- Optional isolated 4-20mA output proportional to the conductivity reading.

» Flow Switch Manifolds

- Optional integrated flow switch manifold may be panel mounted for quick, professional installation with only two process connections.

» Flow Meter Input

- Accommodates a wide range of contacting and Hall Effect water meters

» USB Flashstick Support

- Optional for data logs, event/relay and reset logs, and user configuration file import/export

WCT410 Series | Feed and Bleed Cooling Tower Controller with Dual Biocide Timers

The WCT410 Series offers all of the WCT400 features as well as:

» Programmable Dual Biocide Timers

- Choice of 1, 7, 14, or 28-day cycles
- Able to: add a single biocide at any time or dual alternating biocides, or dual independent biocides

» Alarm Output Relay

- Triggered by low conductivity, high conductivity, or no-flow conditions

Optional USB Features

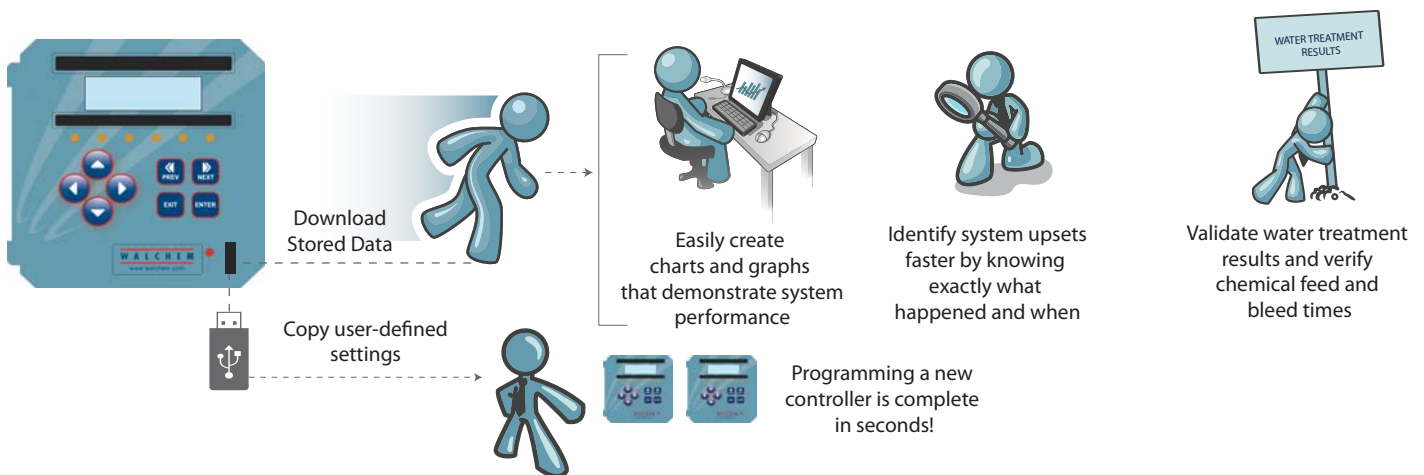

TYPICAL INSTALLATION

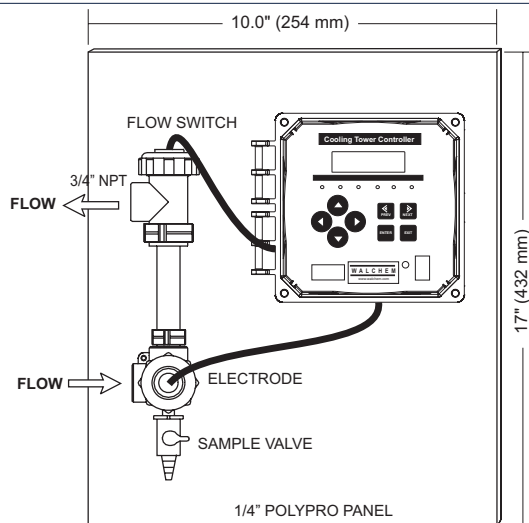
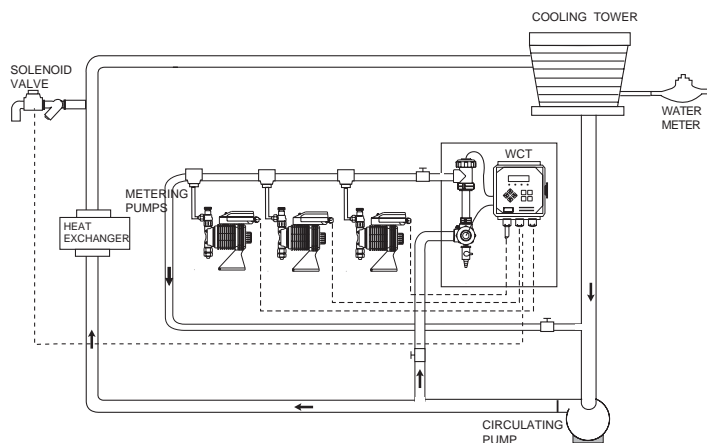

Inputs

Power

100-240 VAC, 50/60 Hz, 8A
Fuse: 1.0 ampere, 5 x 20 mm

Signals

Cond Electrode: 1.0 cell factor, 10K thermistor
Flow Meter (optional): Isolated, dry contact closure required (i.e. relay, reed switch)
Flow Switch (optional): Isolated, dry contact closure required (i.e. reed switch)

Measurement Performance

Conductivity Range 0-10,000 $\mu\text{S}/\text{cm}$
Resolution 1 μS
Accuracy 10-10,000 $\mu\text{S}/\text{cm}$ $\pm 1\%$ of reading
0-10 $\mu\text{S}/\text{cm}$ $\pm 20\%$ of reading
Temperature Range 32 to 158°F (0 to 70°C)
Resolution 0.1 degree
Accuracy $\pm 1\%$ of reading

Flow Switch Manifold & Sensor Specifications

Standard

Process connections 3/4" NPTF
Temperature 140°F (60°C)
Pressure 150 psi up to 100°F (38°C)
50 psi at 140°F (60°C)

Materials of construction

Standard electrode GFRPP, Graphite, FKM
High pressure electrode 316SS, PVDF
Flow switch manifold GFRPP, PVC, Isoplast, FKM
PP/Stainless steel electrode GFRPP, 316SS, FKM
High pressure manifold Carbon steel, Steel

Outputs

Mechanical Relays

WCT400: Two powered relays (Bleed, Feed)
WCT410: Five powered relays (Bleed, Feed, Bio 1, Bio 2, Alarm)
6 A (resistive), 1/8 HP
All relays are fused together as one group, total current for this group must not exceed 6A

4 - 20 mA (optional)

Internally powered
Fully isolated
600 Ohm max resistive load
Resolution .001% of span
Accuracy $\pm 1\%$ of reading

Mechanical

Enclosure Polycarbonate
NEMA Rating NEMA 4X (IP65)
Display 2 x 16 character backlit liquid crystal
Ambient Temperature 32 to 122°F (0 to 50°C)
Shipping weight 7 lbs (3 kg) (approximately)

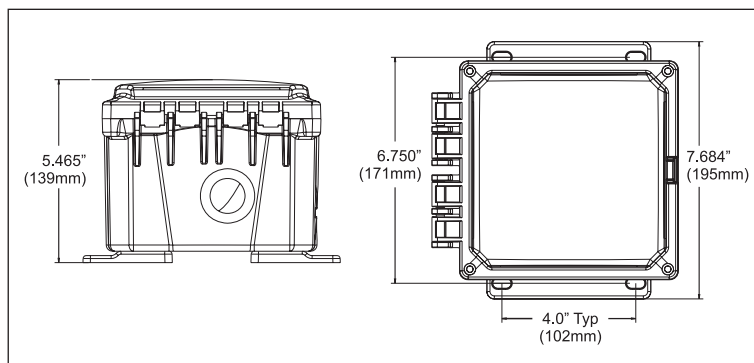

ORDER INFORMATION

WCT400 —
 WCT410 voltage output sensor USB

VOLTAGE

1 = 120 VAC, prewired
 5 = 100-240 VAC, hardwired, cable glands

OUTPUT

N = No data output
 4 = Isolated 4-20 mA output

SENSOR

N = No electrode
 1 = PP/Graphite electrode & tee, 20ft. (6.1m) cable (for in-line or submersion mounting)
 2 = PP/Graphite electrode & flow switch manifold mounted on PP panel, 5 ft. (1.5m) cable
 4 = High pressure electrode (up to 300 psi), 20 ft. (6.1m) cable
 5 = High pressure electrode & flow switch manifold on PP panel, 5 ft. (1.5m) cable
 6= PP/SS electrode & tee, 20 ft. (6.1m) cable
 7= PP/SS electrode & flow switch manifold on PP panel, 5 ft. (1.5m) cable

USB FEATURES

N = Software upgrade capability only
 U = Integrated datalogging, event/reset logging, and configuration file import/export

AGENCY CERTIFICATIONS

UL	ANSI/UL 61010-1:2004, 2nd Edition*
CAN/CSA	C22,2 No.61010-1:2004 2nd Edition*
CE Safety	EN 61010-1 2nd Edition (2001)*
CE EMC	EN 61326 :1998 Annex A*

Note: For EN61000-4-6,-3 the controller met performance criteria B.

*Class A equipment: Equipment suitable for use in establishments other than domestic, and those directly connected to a low voltage (100-240 VAC) power supply network which supplies buildings used for domestic purposes.



WebmasterONE®

WebMasterONE is the most powerful online cooling tower/boiler controllers in the water treatment industry. WebMasterONE couples a multi-I/O platform with Walchem's analytical sensors and extensive communications technologies. The result is the ability to remotely monitor and control your process from any computer, anywhere in the world, with just a standard web browser.

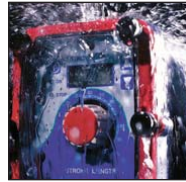

Metering Pumps

Walchem and Iwaki combined their talents to design the most innovative and comprehensive metering pump product line in the world. With over 50 years of combined pump experience, in an array of different markets, the Iwaki-Walchem partnership leverages our strengths to exceed even our toughest customer expectations. Committed to new product development, our pumps are innovative and revolutionary.



WIND WebMaster Industrial Water Controllers

Walchem's WebMaster® Industrial (WIND) Controller sets a new standard for Industrial Water Treatment Controllers. WIND has a flexible multi-I/O platform, a wide range of analytical sensor measurement capabilities, and an extensive assortment of integrated communications and data handling features.



WebAlert Remote Monitor

Walchem's WebAlert is the first stand alone remote monitoring device that can web enable your installed equipment without having to replace or upgrade it.

ABOUT US

Walchem integrates its advanced sensing, instrumentation, fluid pumping and communications technologies to deliver reliable and innovative solutions to the global water treatment market

Our in-house engineering is driven by quality, technology and innovation. For more information on the entire Walchem product line, visit: www.walchem.com



Walchem, An Iwaki America Incorporated Company
 Five Boynton Road Hopping Brook Park
 Holliston, MA 01746 USA
 Phone: 508-429-1110
 Fax: 508-429-7433
www.walchem.com